

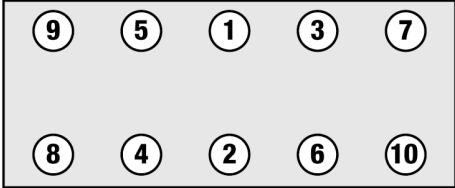

<b>Anziehvorschrift für Zylinderkopf</b>	passend für / suitable for adaptable à / adaptable a  <b>BMW</b>															
<b>Tightening Instructions for Cylinder Head</b>																
<b>Instructions de serrage pour culasse</b>																
<b>Prescripciones de apriete para culatas</b>																
Schraubenkopf / Head shape Tête de vis / Cabeza de tornillo																
	Anziehreihenfolge/Tightening sequence/Ordre de serrage/Orden de apriete															
802.720 M 12 x 157																
<table border="0" style="width: 100%;"> <tr> <td style="width: 10%;">Anziehen/ Tightening/ Serrage/ Apriete</td> <td style="width: 10%;">*</td> <td style="width: 10%;">58 - 62 Nm</td> </tr> <tr> <td></td> <td>●</td> <td>15 min</td> </tr> <tr> <td></td> <td>▶</td> <td>30° - 36°</td> </tr> <tr> <td></td> <td>✱</td> <td>25 min</td> </tr> <tr> <td></td> <td>▶</td> <td>20° - 30°</td> </tr> </table>		Anziehen/ Tightening/ Serrage/ Apriete	*	58 - 62 Nm		●	15 min		▶	30° - 36°		✱	25 min		▶	20° - 30°
Anziehen/ Tightening/ Serrage/ Apriete	*	58 - 62 Nm														
	●	15 min														
	▶	30° - 36°														
	✱	25 min														
	▶	20° - 30°														
Zeichenerklärung / Explanations / Explication / Explicacion																
✱	neue Zylinderkopfschrauben verwenden	use new cylinder head bolts	utiliser des vis neuves	emplar tornillos nuevos												
✱	Warmlauf (80°C)	warm up time (80°C)	chauffage (80°C)	calentamiento (80°C)												
□	Schrauben einzeln lösen und wieder anziehen	loosen and tighten each bolt	deserrer et serrer vis par vis	aflojar y apretar tornillo a tornillo												
●	Setzzeit	relaxation time	durée de tassement	tiempo de espera												
▶	Drehwinkel	torque angle	angle de serrage	ángulo de giro												
<b>Motortyp / Engine type / Type de moteur / Tipo de motor</b>																
Mot. M 10																

# WALLOTHNESCH.COM

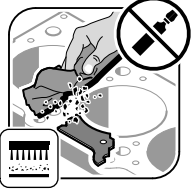
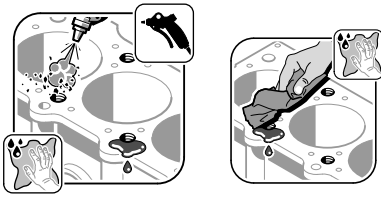

# Nr. 2

1. 

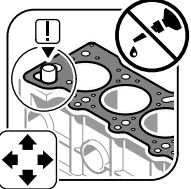
2. 

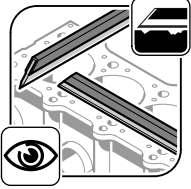

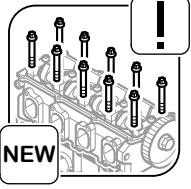
3. 

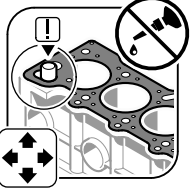

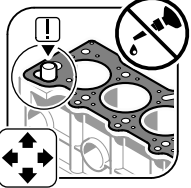
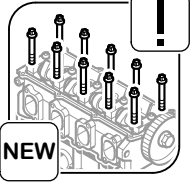
			
R <sub>z</sub>	15-20 µm	11 µm	11-20 µm
R <sub>max</sub>	20-25 µm	15 µm	15-20 µm
W <sub>t</sub>	8-10 µm		
4. 

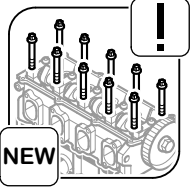
5. 
6. 

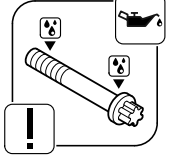

7. 