

<b>Anziehvorschrift für Zylinderkopf</b>	passend für / suitable for adaptable à / adaptable a  <b>BMW</b>															
<b>Tightening Instructions for Cylinder Head</b>																
<b>Instructions de serrage pour culasse</b>																
<b>Prescripciones de apriete para culatas</b>																
Schraubenkopf / Head shape Tête de vis / Cabeza de tornillo																
	Anziehreihenfolge/Tightening sequence/Ordre de serrage/Orden de apriete															
802.700 M 12 x 157																
<table border="0" style="width: 100%;"> <tr> <td style="width: 10%;">Anziehen/</td> <td style="width: 10%;">*</td> <td style="width: 10%;">58 - 62 Nm</td> </tr> <tr> <td>Tightening/</td> <td>●</td> <td>20 min</td> </tr> <tr> <td>Serrage/</td> <td></td> <td>78 - 82 Nm</td> </tr> <tr> <td>Apriete</td> <td>★</td> <td>80°C</td> </tr> <tr> <td></td> <td>▶</td> <td>30° - 40°</td> </tr> </table>		Anziehen/	*	58 - 62 Nm	Tightening/	●	20 min	Serrage/		78 - 82 Nm	Apriete	★	80°C		▶	30° - 40°
Anziehen/	*	58 - 62 Nm														
Tightening/	●	20 min														
Serrage/		78 - 82 Nm														
Apriete	★	80°C														
	▶	30° - 40°														
Zeichenerklärung / Explanations / Explication / Explicacion																
*	neue Zylinderkopfschrauben verwenden	use new cylinder head bolts	utiliser des vis neuves	emplar tornillos nuevos												
★	Warmlauf (80°C)	warm up time (80°C)	chauffage (80°C)	calentamiento (80°C)												
□	Schrauben einzeln lösen und wieder anziehen	loosen and tighten each bolt	deserrer et serrer vis par vis	aflojar y apretar tornillo a tornillo												
●	Setzzeit	relaxation time	durée de tassement	tiempo de espera												
▶	Drehwinkel	torque angle	angle de serrage	ángulo de giro												
<b>Motortyp / Engine type / Type de moteur / Tipo de motor</b>																
Mot. M 30																

# WALLOTHNESCH.COM

# Nr. 3

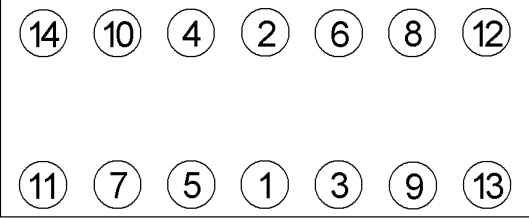

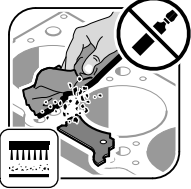
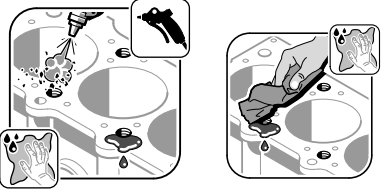

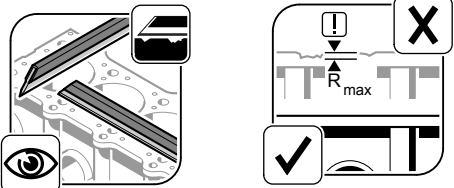
1. 

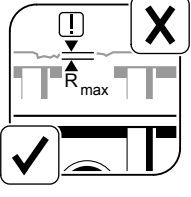
2. 

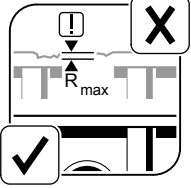



3. 

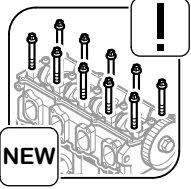
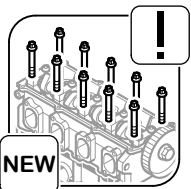

			
R <sub>z</sub>	15-20 µm	11 µm	11-20 µm
R <sub>max</sub>	20-25 µm	15 µm	15-20 µm
W <sub>t</sub>	8-10 µm		
4. 

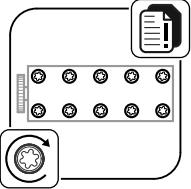
5. 
6. 

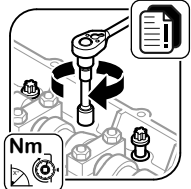

7. 